

Braided Cables Tote

Design by NTmaglia

1 2 3 4 5 6 MODERATELY CHALLENGING

FINISHED MEASUREMENTS

16 inches wide x 15 inches long, excluding handles

MATERIALS

- Drops Garnstudio Paris medium (worsted) weight cotton yarn (1¾ oz/ 82 yds/50g per ball):
10 balls #17 off-white
- Size 7/4.5mm crochet hook or size needed to obtain gauge
- Yarn needle
- ¾-inch-wide x 20-inch-long strips of leather: 2
- 1½-inch wide x 15-inch-long strips corrugated plastic: 2



GAUGE

15 sc = 4 inches; 16 sc rows = 4 inches

PATTERN NOTES

Tote consists of 2 square panels worked in the round and seamed together by a bottom band and by 2 lateral bands (see schematics on page 4).

Stitches for Top Border are worked around Tote edging.

Weave in loose ends as work progresses.

Join with slip stitch as indicated unless otherwise stated.

Chain-3 at beginning of round **does not** count as first treble crochet unless otherwise stated.

SPECIAL STITCHES

Back post treble crochet (bptr): Yo twice, insert hook back to front to back again around vertical post of indicated st, yo, draw up lp, [yo, draw through 2 lps on hook] 3 times.

Front post treble crochet (fptr): Yo twice, insert hook front to back to front again around vertical post of indicated st, yo, draw up lp, [yo, draw through 2 lps on hook] 3 times.

Cross double crochet (cross-dc): Ch 3 (counts as first dc), [sk next st, dc in next st, dc in sk st] across to last st, dc in last st.

TOTE

FRONT PANEL

Rnd 1 (foundation square): Ch 4, **join** (see *Pattern Notes*) to form a ring, ch 3, 2 dc in ring, ch 2, [3 dc in ring, ch 2] 3 times, dc in ring, join in 3rd ch of beg ch-3. (12 dc, 4 ch-2 sps)

Rnd 2 (foundation square): Ch 3 (see *Pattern Notes*), beg in same st as ch-3, [bptr (see *Special Stitches*) in next dc, fptr (see *Special Stitches*) in next dc, (2 dc, ch 2, 2 dc) in next ch-2 sp**, fptr in next dc] around, ending last rep at **, fptr around same dc as beg ch-3, join rnd in first bptr.

Rnd 3: Ch 3, bptr in next bptr, fptr back in each of 3 previous sts, sk next 3 sts (will be worked at end of rnd), *(2 dc, ch 2, 2 dc) in next ch-2 sp, sk next 2 dc, next fptr and next bptr, fptr in each of next 3 sts, bptr in sk bptr, 1 fptr in each of 2 sk dc and in sk fptr*, rep from * to * twice, (2 dc, ch 2, 2 dc) in next ch-2 sp, fptr in each of 3 sts sk at beg of rnd, join rnd in first bptr (to crossover cable in the right way, you'll work last 3 fptr in back of first 3 fptr worked at beg of rnd).

Rnd 4: Ch 3, *bptr in next bptr, sk next 3 fptr, bptr in next st,

fptr in each of the 3 sk fptr, bptr in next dc, (2 dc, ch 2, 2 dc) in ch-2 sp, bptr in next dc, sk 1 dc, fptr in each of next 3 fptr, bptr in sk dc*, rep from * to * 3 times, join rnd in first bptr.

Rnd 5: Ch 3, *bptr in each of next 2 bptr, sk next 3 fptr, bptr in next bptr, fptr back in each of 3 sk fptr, bptr in next 2 dc, (2 dc, ch 2, 2 dc) in next ch-2 sp, bptr in each of next 2 dc, sk next bptr, fptr in each of next 3 fptr, bptr in sk bptr, bptr in next bptr*, rep from * to * 3 times, join rnd in first bptr.

Rnd 6: Ch 3, *bptr in each of next 2 bptr, sk 1 bptr, fptr in each of next 3 fptr, bptr back in sk bptr, bptr in each of next 4 sts, (2 dc, ch 2, 2 dc) in next ch-2 sp, bptr in next 4 sts, sk next 3 fptr, bptr in next bptr, fptr in each of sk fptr, bptr in next bptr*, rep from * to * 3 times, join rnd in first bptr.

Rnd 7: Ch 3, *bptr in next bptr, sk 1 bptr, fptr in each of next 3 fptr, bptr back in sk bptr, bptr in each of next 5 bptr, fptr in next 2 dc, (2 dc, ch 2, 2 dc) in next ch-2 sp, fptr in each of next 2 dc, bptr in each of next 5 bptr, sk next 3 fptr, bptr in next bptr, fptr in each of 3 sk fptr*, rep from * to * 3 times, join rnd in first bptr.

Rnd 8: Ch 3, bptr in next bptr, fptr back in each of 3 previous fptr, sk next 3 fptr (will be worked at end of rnd), *bptr in each of 5 next bptr, sk 1 bptr, fptr in next 3 sts, bptr back in sk bptr, bptr in next dc, (2 dc, ch 2, 2 dc) in next ch-2 sp, bptr in next dc, sk next 3 fptr, bptr in next bptr, fptr in each of 3 sk fptr, bptr in next 5 bptr, sk next 3 fptr and next bptr, fptr in next 3 fptr, bptr in sk bptr, fptr in each of 3 sk fptr*, rep from * to * twice, bptr in each of 5 next bptr, sk 1 bptr, fptr in next 3 sts, bptr back in sk bptr, bptr in next dc, (2 dc, ch



*An eye-catching interplay of
crochet cables creates a striking
flowerlike pattern on the front of
this chic tote. Leather handles add
a classy finishing touch.*

2, 2 dc) in next ch-2 sp, bptr in next dc, sk next 3 fptr, bptr in next bptr, fptr in each of 3 sk fptr, bptr in next 5 bptr, fptr in each of 3 fptr sk at beg of rnd (*to crossover cable in the right way, you'll work last 3 fptr in back of first 3 fptr worked at beg of rnd*), join rnd in first bptr.

Rnd 9: Ch 3, *bptr in next bptr, sk next 3 fptr, bptr in next bptr, fptr in each of next 3 sk fptr, bptr in each of next 3 bptr, sk 1 bptr, fptr in next 3 fptr, bptr back in the sk bptr, bptr in next 2 bptr, fptr in next 2 dc, (2 dc, ch 2, 2 dc) in next ch-2 sp, fptr in each of next 2 dc, bptr in each of next 2 bptr, sk next 3 fptr, bptr in next bptr, fptr in each of next 3 sk fptr, bptr in each of next 3 bptr, sk next bptr, fptr in each of next 3 fptr, bptr in sk bptr, rep from * around, join rnd in first bptr.

Rnd 10: Ch 3, *bptr in each of next 2 bptr, sk next 3 fptr, bptr in next bptr, fptr in each of 3 sk fptr, bptr in next bptr, sk 1 bptr, fptr in each of next 3 fptr, bptr in sk bptr, bptr in each of next 3 bptr, sk next 2 fptr, fptr in each of next 2 dc, fptr in each of 2 sk fptr, (2 dc, ch 2, 2 dc) in next ch-2 sp, sk next 2 dc, fptr in next 2 fptr, fptr in each of 2 sk dc, bptr in next 3 bptr, sk next 3 fptr, bptr in next bptr, fptr in each of 3 sk fptr, bptr in next bptr, sk next bptr, fptr in next 3 fptr, bptr in sk bptr, bptr in next bptr, rep from * around, join rnd in first bptr.

Rnd 11: Ch 3, *bptr in each of next 3 bptr, sk next 3 fptr and next bptr, fptr in next 3 fptr, bptr in sk bptr, fptr in each of 3 sk fptr, bptr in each of next 4 bptr, fptr in each of next 4 fptr, bptr in each of next 2 dc, (2 dc,

ch 2, 2 dc) in next ch-2 sp, bptr in each of next 2 dc, fptr in each of next 4 fptr, bptr in each of next 4 bptr, sk next 3 fptr and next bptr, fptr in each of next 3 fptr, bptr in sk bptr, fptr in each of 3 sk fptr, bptr in each of next 2 bptr, rep from * around, join rnd in first bptr.

Rnd 12: Ch 3, *bptr in each of next 3 bptr, fptr in each of next 3 fptr, bptr in each of next bptr, fptr in each of next 3 fptr, bptr in each of next 4 bptr, sk next 2 fptr, fptr in each of next 2 fptr, fptr in each of 2 sk fptr, bptr in each of next 2 bptr, fptr in each of next 2 dc, (2 dc, ch 2, 2 dc) in next ch-2 sp, fptr in next 2 dc, bptr in next 2 bptr, sk next 2 fptr, fptr in next 2 fptr, fptr in each of 2 sk fptr, bptr in each of next 4 bptr, fptr, in each of next 3 fptr, bptr in next bptr, fptr in next 3 fptr, bptr in each of next 2 bptr, rep from * around, join rnd in first bptr.

BACK PANEL

Rnd 1: Ch 4, join to form a ring, **ch 3** (*does not count as first dc*), dc in ring, ch 2, [3 dc in ring, ch 2] 3 times in ring, dc in the ring, join in 3rd ch of beg ch-3. (12 dc, 4 ch-2 sps)

Rnd 2: Ch 3, *fptr in each of next 2 dc, (2 dc, ch 2, 2 dc) in next ch-2 sp, fptr in next dc, rep from * 3 times, join rnd in first bptr. (12 fpdc, 16 dc, 4 ch-2 sps)

Rnds 3–12: Ch 3, fptr in each fptr and each dc to ch-2 sp, (2 dc, ch 2, 2 dc) in ch-2 sp, [fptr in each fptr and dc to next ch-2 sp, (2 dc, ch 2, 2 dc) in ch-2 sp] around, fptr in each rem fptr, join rnd in first fptr.

At the end of last rep, fasten off.

BOTTOM

Row 1 (RS): Join in corner ch-2 sp of Back Panel, **ch 3** (*counts as first dc*), dc in each of next 47 sts across edge, dc in next corner ch-2 sp, turn. (49 dc)



Front of Tote

Row 2: Ch 3 (count as bptr), bptr in each of next 48 sts, turn.

Row 3: Ch 3 (count as fptr), fptr in each of next 48 sts, turn.

Row 4: Ch 3 (count as bptr), bptr in each of next 48 sts, leaving 24-inch length, fasten off.

Thread yarn needle with rem length, **whipstitch** (see illustration) row 4 of bottom to rnd 12 of Front Panel across straight edge.

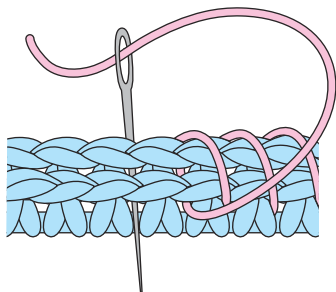

Whipstitch Edges

SIDE PANELS

Make 2.

Row 1: With WS facing and working in side edge of rows of Bottom, join yarn, **ch 3** (counts as first dc), work 9 dc evenly sp across, turn. (10 dc)

Row 2: Ch 3, bpdcc in each st across, turn.

Row 3: Ch 3, fpdc in each st across, turn.

Row 4: Rep row 2.

Row 5: Ch 3, fptr in same st as beg ch-3, fptr in each st across to last st, 2 fptr in last st. (12 fptr)

Rows 6 & 7: Rep rows 2 and 3.

Row 8: Rep row 2.

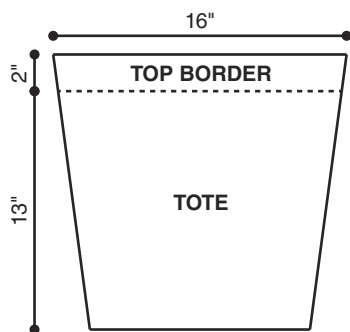

Row 9: Rep row 5. (14 fptr)

Rows 10 & 11: Rep rows 2 and 3.

Row 12: Rep row 2.

Row 13: Rep row 5. (16 fptr)

Rows 14 & 15: Rep rows 2 and 3.

Row 16: Rep row 2.

Row 17: Rep row 5. (18 fptr)

Rows 18 & 19: Rep rows 2 and 3.

Row 20: Rep row 2. Fasten off.

Whipstitch Side Panels to each side of Front and Back Panel

TOP BORDER

Rnd 1: With Back Panel facing, join in first st Side Panel, ch 1, working around entire outer top edge, work 132 sc sts, join in beg sc.

Rnds 2–6: Ch 1, sc in each sc around, join in beg sc.

Rnd 7: Cross-dc (see *Special Stitches*) in each st around, join in beg dc.

Rnds 8–13: Ch 1, sc in each st



Back of Tote

around, join in beg sc.

At the end of rnd 13, leaving 30-inch length, fasten off.

ASSEMBLY

Fold Top Border along rnd 7 to inside of Tote, position corrugated plastic between layers of fold. Whipstitch rnd 13 to bottom edge of rnd 1 of Top Border.

Punch 4 holes in each end of both leather strips.

Center each end of handle between rnds 1 and 2 of Top Border leaving 7-inch sp at center between ends. Sew handle to Tote, rep with rem handle on opposite side of Tote. **CW**

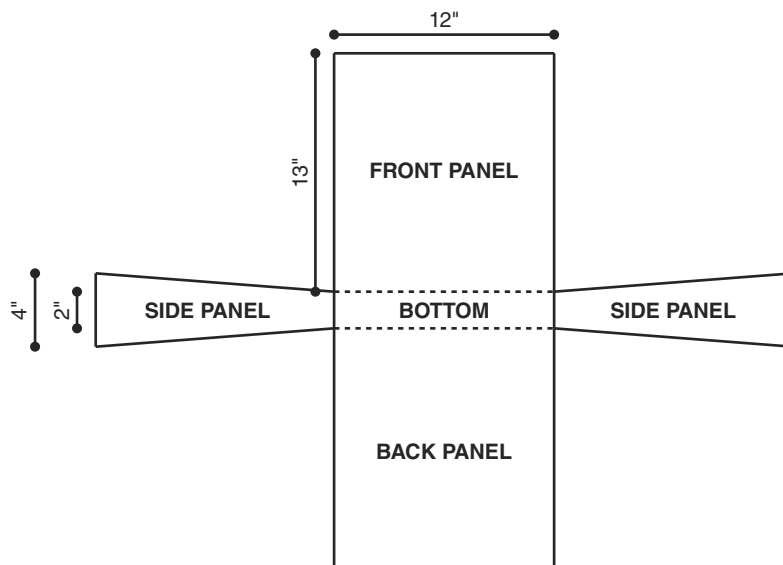

STITCH GUIDE

Need help? StitchGuide.com • ILLUSTRATED GUIDES • HOW-TO VIDEOS

STITCH ABBREVIATIONS

beg	begin/begins/beginning
bpdc	back post double crochet
bpsc	back post single crochet
bptr	back post treble crochet
CC	contrasting color
ch(s)	chain(s)
ch	refers to chain or space previously made (i.e., ch-1 space)
ch sp(s)	chain space(s)
cl(s)	cluster(s)
cm	centimeter(s)
dc	double crochet (singular/plural)
dc dec	double crochet 2 or more stitches together, as indicated
dec	decrease/decreases/decreasing
dtr	double treble crochet
ext	extended
fpdc	front post double crochet
fpdc	front post double crochet
fpdc	front post double crochet
fptr	front post treble crochet
g	gram(s)
hdc	half double crochet
hdc dec	half double crochet 2 or more stitches together, as indicated
inc	increase/increases/increasing
lp(s)	loop(s)
MC	main color
mm	millimeter(s)
oz	ounce(s)
pc	popcorn(s)
rem	remain/remains/remaining
rep(s)	repeat(s)
rnd(s)	round(s)
RS	right side
sc	single crochet (singular/plural)
sc dec	single crochet 2 or more stitches together, as indicated
sk	skip/skipped/skipping
sl st(s)	slip stitch(es)
sp(s)	space(s)/spaced
st(s)	stitch(es)
tog	together
tr	treble crochet
trtr	triple treble
WS	wrong side
yd(s)	yard(s)
yo	yarn over

YARN CONVERSION

OUNCES TO GRAMS	GRAMS TO OUNCES
1.....28.4	25.....7/8
2.....56.7	40.....1 1/2
3.....85.0	50.....1 3/4
4.....113.4	100.....3 1/2

UNITED STATES UNITED KINGDOM

sl st (slip stitch)	=	sc (single crochet)
sc (single crochet)	=	dc (double crochet)
hdc (half double crochet)	=	htr (half treble crochet)
dc (double crochet)	=	tr (treble crochet)
tr (treble crochet)	=	dtr (double treble crochet)
dtr (double treble crochet)	=	ttr (triple treble crochet)
skip	=	miss

Single crochet decrease (sc dec):
(Insert hook, yo, draw lp through) in each of the sts indicated, yo, draw through all lps on hook.

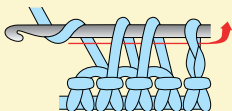

Example of 2-sc dec

Half double crochet decrease (hdc dec):
(Yo, insert hook, yo, draw lp through) in each of the sts indicated, yo, draw through all lps on hook.

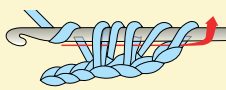

Example of 2-hdc dec

Double crochet decrease (dc dec): (Yo, insert hook, yo, draw lp through, yo, draw through 2 lps on hook) in each of the sts indicated, yo, draw through all lps on hook.

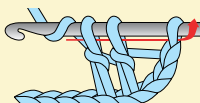

Example of 2-dc dec

Treble crochet decrease (tr dec): Holding back last lp of each st, tr in each of the sts indicated, yo, pull through all lps on hook.

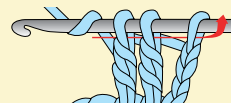

Example of 2-tr dec

Reverse single crochet (reverse sc): Ch 1, sk first st, working from left to right, insert hook in next st from front to back, draw up lp on hook, yo and draw through both lps on hook.

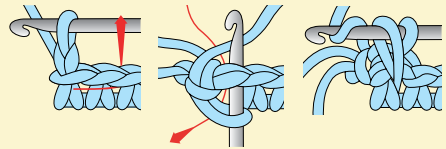

Chain (ch): Yo, pull through lp on hook.

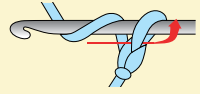

Front loop (front lp) Back loop (back lp)

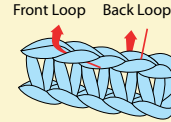

Slip stitch (sl st): Insert hook in st, pull through both lps on hook.

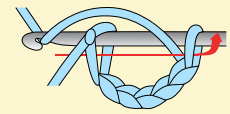

Single crochet (sc): Insert hook in st, yo, pull through st, yo, pull through both lps on hook.

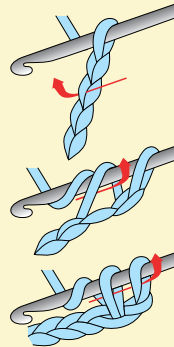

Front post stitch (fp): Back post stitch (bp): When working post st, insert hook from right to left around post of st on previous row.

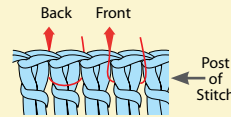

Chain color change (ch color change)
Yo with new color, draw through last lp on hook.

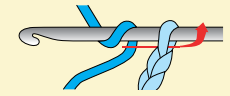

Half double crochet (hdc): Yo, insert hook in st, yo, pull through st, yo, pull through all 3 lps on hook.

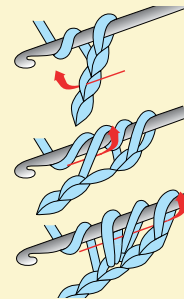

Double crochet color change (dc color change)
Drop first color, yo with new color, draw through last 2 lps of st.

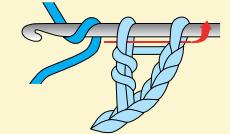

Double crochet (dc): Yo, insert hook in st, yo, pull through st, [yo, pull through 2 lps] twice.

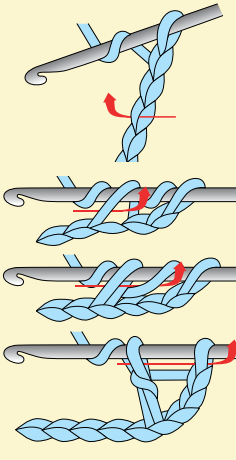

Double treble crochet (dtr): Yo 3 times, insert hook in st, yo, pull through st, [yo, pull through 2 lps] 4 times.

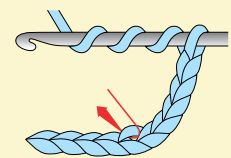

Treble crochet (tr): Yo twice, insert hook in st, yo, pull through st, [yo, pull through 2 lps] 3 times.

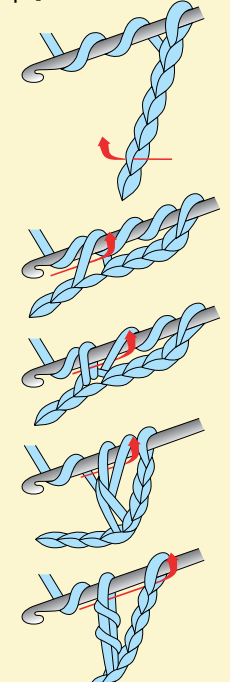



Published by Annie's, 306 East Parr Road, Berne, IN 46711. Printed in USA. Copyright © 2016 Annie's. All rights reserved. This publication may not be reproduced in part or in whole without written permission from the publisher.

Every effort has been made to ensure that the instructions in this publication are complete and accurate. We cannot, however, take responsibility for human error, typographical mistakes or variations in individual work. Please visit AnniesCustomerService.com to check for pattern updates.